

INTERNET OF THINGS AND WEB SERVICES FOR CURRENT PANDEMIC CHALLENGES: AN EXPLORATORY STUDY

AJAY NAIN ¹, ROHIT MALIK ², SOPHIYA SHEIKH ³ and PAWAN BHAKER ⁴

^{1, 2, 3, 4} School of Computer Applications Lovely Professional University, Phagwara, India.

Email: ¹mr.ajaynain@gmail.com, ²rohitxmalik7@gmail.com, ³sophiyasheikh@gmail.com,

⁴pawanbhaker88@gmail.com

Abstract

The internet of Things (IoT) plays a significant role in the world's major fields, including the economy, the medical field, weapon systems, social networks, and other potential avenues for human interaction. The issues that the entire world is currently dealing with because of the pandemic are managed substantially by the IoT. In the Covid-19 scenario, systems based on the internet of things are used to monitor patients to preserve the protocols. In addition, a variety of web-based applications are acquired to interact with individuals and assist them in locating solutions to the numerous problems that have arisen during the lockdown period. Intensive research has been conducted using IoT and web services to address the potential challenges that arose during the Covid-19 conference. This paper presents an exploratory analysis of using the Internet of Things and Web Services to address pandemic challenges. In addition, we present a statistical analysis that employs IoT devices to find solutions to current pandemic issues. Moreover, we depict how web services are currently used to gather data, identify, and provide precise information in each area or globally to handle pandemic concerns

Index Terms: Internet of Things, IoT, Web-Services, Covid-19, Pandemic Challenges.

I. INTRODUCTION

The term "IoT" can be defined as a collection of various techniques that automatically operate in a network without human interaction. The term IoT is also described as the connection between two computing devices working using the internet. These devices are embedded in everyday objects and used to send and receive data [1]. Besides, IoT has recently acquired significant attention and strong research support in a variety of academic, industrial, technological, economic, political, and other social areas. But in the sphere of medical sciences, the usage of IoT has drastically changed how individuals are treated [2]. Additionally, more customized systems have taken the place of traditional diagnosis techniques, improving patient monitoring and treatment. As an Identify applicable funding agency here. If none, delete this.

Result, diagnosing each person is now easier than it used to be. Internet of Medical Things (IoMT) is now playing a major role in the medical sector. It provides lower expenses for IoT-based devices and much better services than conventional systems. It also includes various advanced features and an efficiently understandable user experience. In the IoT, there is no limit to the number of connected devices. It all comes down to transferring data or sending useful information between devices. However, for the effective use of data, several other technologies must work together. Resultantly, IoT is a collection of a variety of technologies and domain knowledge [3].

The IoT has recently developed a plethora of medical devices whose functions have garnered considerable attention in the healthcare sector. These devices play an important role in dealing with various stages of infectious disease. For instance, during the covid-19 pandemic, patients must be actively engaged with their physicians during the different phases of the disease. In this study, we evaluate the role of IoT and web services technology in the Detect, Trace/Track, Recovery, and Vaccination phase of the COVID-19 response. Since COVID-19 is very contagious, therefore even a person without any symptoms can quickly carry the virus during the first phase. This phase is the detection of COVID-19, and a quicker diagnosis is needed during this phase. When a patient is diagnosed quickly, the virus can be kept under control and the right treatment can be given to the patient efficiently. IoT devices can speed up detection by collecting information about the patient. This can be done by taking body temperatures with various tools, getting samples from people who might be sick, and so on. Once a patient with COVID-19 has been found, the second phase, called "track/trace," is a very important stage of the disease during which he or she must be kept away from other people for the duration of treatment. In this phase, IoT devices can check on patients remotely to see how their treatments are going and if they are following the authorities' orders to stay at home. Also, they can clean places without help from people. Some of these are the use of tracking wristbands and devices that can clean the air. The Centers for Disease Control and Prevention (CDC) [4] says that most people with mild symptoms can get better on their own without treatment, but there is no guarantee that they won't get sick again. COVID-19 symptoms may change if you get re-infected. Concerning these possible re-infections during the post-recovery phase, the chance of symptoms coming back and the risk of spreading the disease can be high. To stop this, social distancing needs to be followed with the help of IoT devices. Some examples are bands and crowd monitoring devices that follow people and keep the right distance. During the COVID-19 epidemic, IoT technology has been used to help patients, medical professionals, and government officials.

Moreover, many devices made with IoTs are very useful and can help patients to fight disease smartly. Smart goggles, helmets, wearables, thermometers, robots, and drones are a few names. People can find and track infected people with these devices, and they can also help them to get better. During the early detection phase, devices like smart helmets, goggles, and thermometers can be very helpful. These devices will help people to find others who are showing signs of having the virus. If the virus is caught early, it won't spread as much. Similarly, robots, drones, and wearables can be used to keep an eye on patients, find people who are close to them, and keep track of them during all stages of the virus. Besides, web services are an essential technology that helps a lot in the fight against covid.

Web services can be defined as a compilation of diverse standards and open protocols that facilitate the exchange of data among programmes or systems [5]. Several web services are currently employing machine learning techniques in order to detect and diagnose various respiratory conditions, such as tuberculosis and asthma. Organisations have utilised diverse web services and Internet of Things (IoT) technologies to adapt the original solution for addressing the ongoing pandemic. The implementation of Internet of Things (IoT) and web-

based services has mitigated the risks associated with this widespread disease. The COVID-19 pandemic is considered to be one of the most significant global health crises in recent history, comparable in scale to the influenza crisis of 1918 and the SARS (severe acute respiratory syndrome) epidemic of 2003. Based on the World Health Organization's (WHO) reports as of August 2022, the number of confirmed cases of covid-19 has exceeded 606 million, accompanied by a substantial mortality rate of approximately 6.4 million. The primary factor contributing to the high number of cases and fatalities is the transmission of infection through human-to-human contact. The presence of both symptoms and non-symptomatic carriers contributes to heightened levels of contamination. Hence, the utilisation of Internet of Things (IoT) technology, Artificial Intelligence (AI), and web-based services for the management of the Coronavirus is comparatively more efficacious and secure.

In this paper, we performed a systematic survey of the various IoT devices that are useful in various tasks to eliminate the contamination of covid-19 among people. We've divided this paper into various phases and classified the uses of various IoT devices accordingly. The focus of this paper is to include and specify the needed IoT devices that are being used to protect people and create awareness among them. Furthermore, we present the working of these devices and their contribution to helping patients in society this survey will help people understand what devices are useful in which scenarios, which devices are used in early detection of covid-19, and which devices will help in contamination prevention, and which devices will help in virus treatment. We have also performed the inclusion of web services and their utility in the same direction

The rest of the paper is organized as follows: Section 2 presents related work and Motivation, Section 3 depicts Detect phase, Section 4 specifies the tracking phase, Section 5 shows the Recovery phase, and Section 6 presents vaccination phase, Section 7 describes the role of web services in detect, tracking, recovery phase. The analysis is concluded in Section 8.

II. RELATED WORK

The threat of viruses like this has been with us for a very long time. There is a new global conflict every 100 years, a new virus that is even more lethal than the last one. The Internet of Things and artificial intelligence will aid the fight against these viruses and has grown less difficult as people have more tools at their disposal to maintain social distance and take care of their overall health. These devices help people to take protection measures without spreading the disease.

Several different virus strains infect humans across the globe. A variety of factors contribute to them, but the most significant impact is on the public. These viruses are most dangerous to both humans and other creatures and have a propensity to rapidly reproduce their species. These Viruses include characteristics such as the ability to spread from animals to people and back again. It is easier to combat viruses like this today than it was in the past. If we discuss previous viral pandemics and their causes, unfortunately, there is no way to identify the infection, help those who are ill or raise public awareness of pandemics. There is various type of disease it may have a global impact all at once. There are plenty that has evolved

into a threat to the globe, as seen by the 1918 influenza pandemic and the 2019 covid-19 virus. When novel influenza or other illness arises, it quickly becomes widespread. However, its first stages are difficult to identify and manage. It is also difficult to cure because of a lack of knowledge about the virus or its strains. Some of the details of these viruses are obtained from literature and are given as follows.

Ebola virus: It is one of the same kinds of virus and causes the disease known as Ebola hemorrhagic fever, which was first identified in 1976. The Republic of the Congo and Sudan were the first epicenters of the Ebola virus's spread throughout Africa. Human-to-human transmission of Ebola from the fluids or blood of sick people or animals to other people. In 1976, the first fatal epidemic of the Ebola virus [6] was documented.

Extreme variation exists within its strain, with a death rate of 71

Eliminating the Effects of Ebola Applying Web-Services with the Internet of Things: The war against Ebola employs both curative medicine and supportive care. Right now, two medications have received US government approval for Ebola virus care and treatment. Imzab [7] is the first, and it's a compound. The first medicine is a combination of three different monoclonal antibodies, while the second drug is a single monoclonal antibody referred to as Ebanga. IoT and cloud services are actively utilized for constant, remote monitoring of patients. Radio Frequency Identification equipment is employed throughout the diagnosis, treatment, and rehabilitation stages. Technology like cloud computing, wearable sensors, and RFID (Radio-Frequency Identification Device) is employed throughout the process.

HIV (Human Immunodeficiency Virus): HIV [8], which first emerged in the 1980s, is the deadliest virus ever recorded. A virus that can infect human cells. Effects on Humans system, particularly the T-Cells that aid the immune system in fighting illness. Damaged by this virus are the T-Cells.

Infection with HIV Treatment Applying the Concepts of Web Services with the Internet of Things: Although there is currently no cure for HIV, the virus can be managed with treatment. With proper treatment, HIV can be managed by the majority of patients in as little as six months. Medicines that work to stop the spread of STDs in general. Medicines for HIV are Antiretroviral therapy for short (ART). Because HIV can only be transmitted by bodily fluids or the secretions of an infected animal or human, there is no direct use of IoTs in HIV therapy. Cloud computing is useful in this situation since it allows us to provide people with the facts, spread the word, and get them to pay attention to the time constraints.

Hantavirus: This virus [9] first came to public attention in 1993. Although it can be spread from one infected person to another, however, this virus is not as contagious as others because it spreads through exposure to an infected object, such as contaminated mice's saliva. The lung form of Hantavirus is commonly referred to as simply "Hantavirus Pulmonary Syndrome."

SARS-CoV: This Virus First Came to Light in 2002 and de-scribes the extreme nature of the virus that causes severe acuterespiratory illness [10]. Humans, bats, and other mammals shared a coronavirus species called SARS-CoV. This virus is representative of the RNA virus family.

IoT and other Web services technology in defeating SARS- CoV: An abundance of pharmaceuticals produced with the aid of the convenience of Internet of Things technologies. Companies can now acquire accurate information from the Web-services. Besides, accuracy in describing the various aspects and other details of the virus that need to be known. Rotavirus: It's an RNA virus with two copies of their genetic material, like other members of the Reoviridae family. Among kids, this is a big health issue. This virus primarily has a high fatality rate among babies. Common symptoms in children infected with the Rotavirus [11] may have nausea, vomiting, diarrhea, fever, and pain in the gastrointestinal region. It arrived in 2008's spotlight. RV5 and RV1 are just two of the vaccinations against the virus that is now available on the market whereas, the dosages vary depending on timing.

Inclusion of IoT-based gadgets in rotavirus: Doctors can keep track of their patient's health and any changes that may occur by various IoT devices. Besides, web services also aid in compiling the record of virus-related data that is now available. Thereafter the era of Covid-19 arises in 2019. Intensive research has already been included in the literature to identify the impact of covid-19 and solutions using IoT and AI.

The author of [12] tried to investigate the role of artificial intelligence in the analysis, preparation, and fight against COVID- 19 (Coronavirus) and other pandemics. Because of this, the authors have uncovered seven important applications of AI in the fight against the COVID-19 pandemic. By compiling and examining all available data in the past, this technology plays a significant part in determining whether a cluster of cases exists or not and in determining where the virus will strike in the future. In addition, the author concluded that healthcare organizations require decision-making technologies to effectively manage the COVID-19 virus and assist them in obtaining appropriate recommendations in real-time in order to halt the spread of the virus.

To combat the COVID-19 pandemic, the authors of [13] proposed a step-by-step process chart that includes the following steps: healthcare data tracking for remote areas; virtual gatherings and communications; controlling and analyzing the information received; and taking actions based on the reports received. The author of [14] provided a concise overview of many different technologies that were discovered to be helpful during the covid pandemic. These technologies include big data, cloud computing, artificial intelligence, actuators, smart sensors, software, and virtual reality/augmented reality.

The author went on to discuss how these technological advancements [15] helped even while the pandemic was still active. The treatment of patients, the storage of data about covid patients, accurate decision making, the monitoring of patient statistics, the detection of disease, the detection of attacks, smart beds, assistance in remote areas, and other applications are also being discussed.

Motivation: The Internet of Things and web services play a significant role in the fight against the deadliest viruses in several ways. It aids in diagnosis, therapy, and recovery for those infected with the virus. Still, there are some infections that we have not been able to encounter threats far more severe than SARS's CoV-2 covid. Although the Covid virus was resisted, ultimately machine learning and artificial intelligence based on the IoT were used to great advantage, allowing users to gain insight into previously unknown data. In this chain, the government decides on safety measures and standards to implement to reduce the number of infections.

The utilisation of the Internet of Things has become prevalent in contemporary healthcare facilities for the purpose of managing and addressing viral infections and various other ailments. Ventilators, nurse robots, sanitising drones, mopping robots, and various other Internet of Things (IoT) devices exemplify the range of technologies available. Among these, MRI and ECG scanners, as well as heart rate monitors, serve as notable instances of IoT devices.

The main motivation behind performing this research on the topic of covid-19-based IoT devices is to create awareness among people about various helpful devices and give insights about the working of these devices. Even if no "miracle formula" is discovered, this survey can be beneficial for future developments, can shed light on issues that are either widely or rarely discussed, and can improve society as a whole.

III. DETECT

The diagnostic phase begins with the detection phase, which is the most crucial and first phase. The detection stage aids specifically in determining the infection rate or the rate at which the infection is spreading [16] in a certain area. There are a variety of apps and wearables that can be used in the detection phase introduced during lockdown periods. These developments can aid governments in analyzing people's health data gleaned from a variety of IoT-based apps and web services. It's not everyone's cup of tea to do a thorough, one-on-one evaluation of every person, but with these wearable objects and software, detection is a breeze. Since covid-19 is a global pandemic and not a regional health issue; therefore, these tools are very useful in clarifying the precise numbers of infected people. Various tools and applications can be utilized during this phase as discussed below:

A. Wearables

It is a device that helps to find information about the person itself. Some of the wearables are discussed below:

- 1) *Smart Helmets:* Studies have shown that smart helmets [17] significantly reduce the risk of head trauma. When the helmet's camera detects a person's body heat, it immediately records that person's GPS coordinates and snaps a photo of them. Its significant utility stems from its ability to show the infected person or a person exhibiting similar symptoms of covid-19. The infected person's recent movements can be tracked by injecting or implementing a location history feature. A basic workflow diagram is shown in fig 1.

2) *Smart Goggles*: A further useful IoT device is smart goggles. This smart eyewear is superior to thermometers since they require less engagement from the user [18]. The built-in face recognition and thermal scanning feature of this eyewear make it easier to locate potentially contagious or sick individuals in crowded settings. These glasses incorporate a data chip that can be used to record information about a person, including their facial features, for eventual identification. When used in large numbers, these glasses are ideal for detecting contamination in a crowd. Some of the examples of smart goggles and helmets are shown in Fig.2. Smart Goggles thermal imaging device consists of a few necessary parts: the optics, sensors and detectors, amplifying mechanism, signal processor, and screen. Moreover, it can have additional protection such as a layer of rubber, sealed housing, etc.

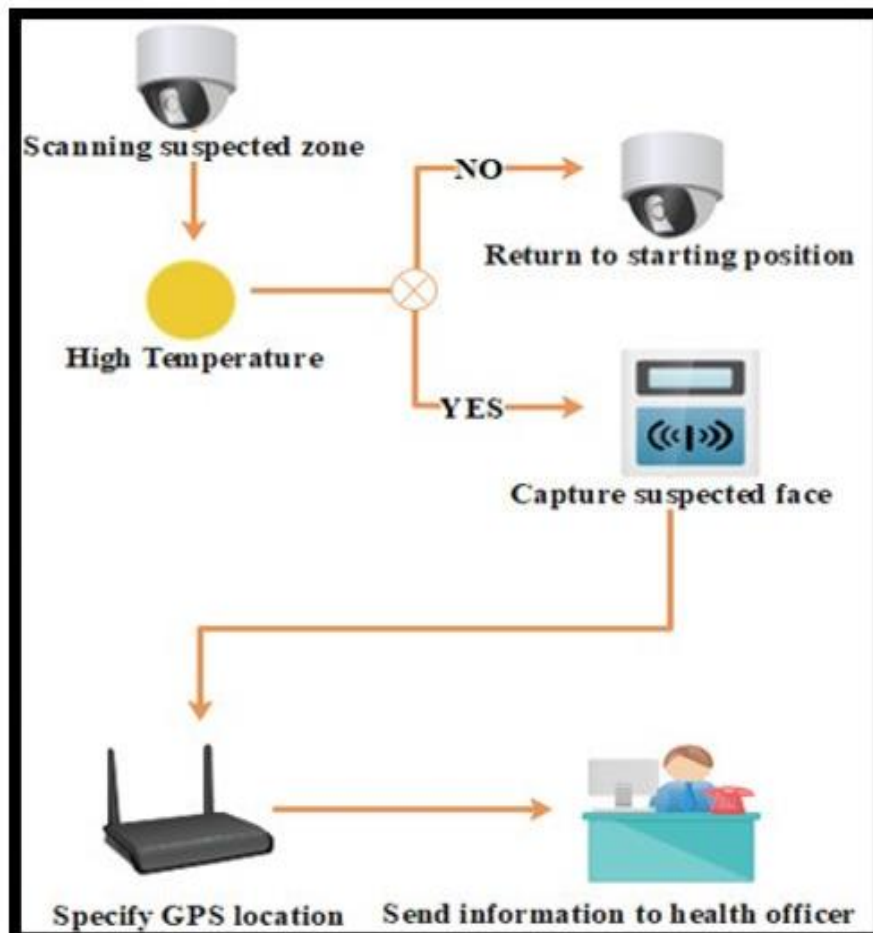

Figure 1: Work Flow of Smart Helmet



Figure 2: Smart Helmets and Goggles

- 3) *Smart Thermometers*: These pocket-sized thermometers [19] are ideal for use in screening individuals since they are low-cost, space-efficient, and accurate to within a few degrees. Many people's data can be stored in these thermometers simultaneously. They're helpful since they allow people to maintain social distance while testing for their thermal intensity, unlike infrared thermometers, where people are closer together. There are infrared thermometers that can reduce the risk of the infection spreading further. Some of the examples of smart thermometers are shown in Fig.3.

B. Drones

Drones are just as handy as the other gadgets out there. Rapid screening of large numbers of people is usually preferable since it relieves the stress of widespread contamination and allows infected or symptomatic individuals to be isolated as soon as feasible. A better rate of recovery is another benefit of early diagnosis. Drones are also known as unmanned aerial vehicles (UAVs) [20]. These devices can be employed for the purpose of screening individuals in locations that are not readily accessible to humans, thereby mitigating the necessity



Figure 3: Smart Thermometers



Figure 4: Thermal Scanning Drones

For human interaction, a characteristic that is relatively more pronounced in the context of thermometers. These may be more useful for locating polluted areas and speeding up the screening of persons. Drones with thermal imaging capabilities can be quite helpful for crowd screening in densely populated regions. Some of the examples of Drones are shown in Fig.4.

C. Robots

In the context of speculative fiction, a robot with a human-like appearance and the ability to mimic human movement and perform human tasks autonomously. One of the greatest benefits of robots [21] is that they free up human workers from some of their labor. Robots serve a crucial role and are incredibly helpful in many ways as we all battle a dire scenario. Because it operates in people's environments, it lessens the burden on individuals and lessens the likelihood that an individual would catch an infection from another person. These robots can also act as intermediaries in a variety of situations involving two-way conversations. Although humans aren't necessary at any point in the covid timeline, robots play



Figure 5: Robots

A key role throughout. During the testing phase of detection, it collects samples from people's throats as shown in fig 5.

IV. TRACE/TRACK

To prevent the rapid spread of the pandemic, tracking individuals is performed using various methods or apps. A wide variety of IoT devices and services, as well as any other kind of web service, can be used to perform the tracking. Sensing, reporting, and tracking an individual's particulars are the four main ways from which the tracking phase can begin. Various web services and apps built on the IoT can be used to perform either individual scanning or mass tracing. Certain smartphone applications have the potential to assist individuals in self-diagnosing medical conditions by allowing them to assess their symptoms. Additionally, the

tracking of large populations can be facilitated through the utilisation of diverse surveillance devices such as thermal detectors, smart thermometers to measure and wearable technology. The data that has been acquired can be utilised to ascertain the present circumstances of individuals. Here are some devices/applications which are mainly used to handle pandemic situations:

A. Smart Applications

Tracking and detecting infected people are facilitated by Smartphone Applications [22] that utilize data from GIS and GPS systems. Governments use a plethora of apps to keep track on covid patients and keep in touch with medical staff. These programs facilitate patient monitoring and travel log keeping. Smartphone apps make it simple to look up where the nearest containment zone is and where any covid patients might be located. The following software is used in pandemic response:

- 1) *Aarogya Setu*: The Government of India's Ministry of Information Technology and Electronics created the app [23] to warn people if they encounter someone who has tested positive for coronavirus. Bluetooth is used to do the tracking and users are given directions about infected people. It's necessary to enable Bluetooth and our current location after we've downloaded and installed the app on our phones. This program allows us to test ourselves by responding to a series of questions. If this question is answered in a way that suggests exposure to covid-19, the data is transmitted to government servers. The app also includes guidelines for self-quarantine.
- 2) *Trace Together*: In order to acquire the widely used TraceTogether [24] application, it is necessary to possess a smartphone equipped with Bluetooth functionality and a Singaporean mobile number. This application utilises a contact tracing technique to inform users about any recent, substantial, and potentially contagious encounters they may have had with an individual who has tested positive for a particular condition. Neither the user's current location nor their Wi-Fi or mobile network information is recorded by the app. When two people are close together, their phones will use Bluetooth to temporarily swap identification numbers. The User's ID is encrypted using a secret key held by the Singapore Ministry of Health (MOH) to produce this temporary identifier.
- 3) *Covid Watch*: The Stanford University community in California has had an impact on the creation of the Covid Watch [25] app. Using this app, users can monitor their personal information and health without encountering potentially infected people. The wearer is alerted discreetly via Bluetooth when they are near a "positive" person, as detected by the Covid Watch.

The applications used by various countries with their functions is shown in table 1.

- 4) *The Corona Dataspende*: The German government commissioned the development of a coronavirus-tracking app called covid Dataspende [26] that also tracks users' core temperatures, heart rates, and sleep patterns. This app monitors a person's health data by means of wearable devices like smartwatches and fitness bands.

B. Drones

Drones of various kinds are being used to combat epidemics. In the event of a pandemic, drones are used for the following specialized functions. Drone technology has the potential to lessen the need for human intervention and access to previously inaccessible areas. For the purposes of covid-19's medical sciences, surveillance drones [34] best belong in the IoT category of tracking. The thermal scanners on board these drones allow them to monitor a large crowd all at once or to focus on specific individuals. A data unit of people tracked by these drones can be used to examine the symptomatic members of the crowd. This straightforward block diagram (Fig. 6) explains the functions of these drones. A drone is employed for the purposes of surveillance, search operations, detection tasks, and a range of other applications. This technology employs Global Positioning System (GPS), cameras, and advanced computational capabilities. A quad-copter or drone [35] is comprised of various essential components, including a flight controller, an RC receiver (remote controller)/transmitter, a Raspberry Pi (RPI), a Lidar Lite, an

Table I: List of Applications Utilized During Covid 19

List of Applications			
App Name	Origin Country	Functions	References
Aarogya Setu	India	<ul style="list-style-type: none"> • Checks Pulse rate, sleep patterns, Body Temperatures • Tracks People using smartwatches or fitness bands 	[27]
Corona Dataspende	Germany	<ul style="list-style-type: none"> • Checks Pulse rate, sleep patterns, Body Temperatures • Tracks People using smartwatches or fitness bands 	[28]
Trace Together	Singapore	<ul style="list-style-type: none"> • Tracking people using encryption IDs • Access users' information • Providing notification alarms when in proximity with infected people 	[29]
Covid Watch	Arizona	<ul style="list-style-type: none"> • Track people according to their travel history 	[30]
HaMagen	Israel	<ul style="list-style-type: none"> • Uses contact tracing to track people • Gives record of 15 days of location 	[31]
Social Monitor-ing	Russia	<ul style="list-style-type: none"> • Track Patients infected with covid-19 • Access the users information 	[32]
Stop Corona	Croatia	<ul style="list-style-type: none"> • Helps in Finding Contamination zones • Getting daily health reports 	[33]

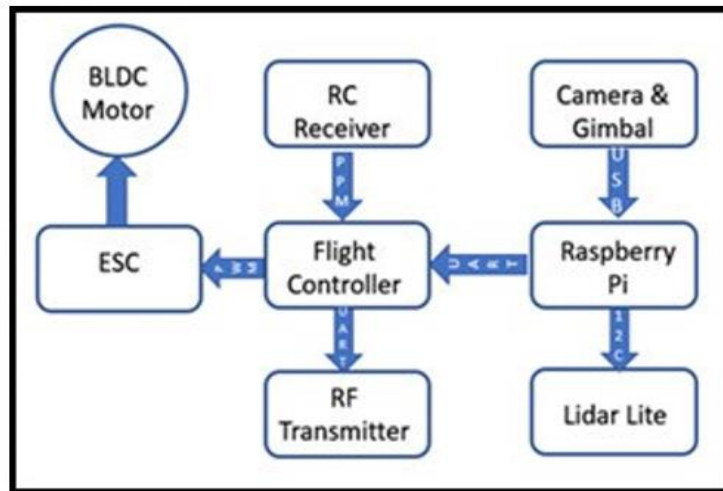

Figure 6: Constructive model of Drone

RF Transmitter, a BLDC motor, a Camera, and a Gimbal. The flight controller serves as a central component of the drone system. The system collects data and instructions from various sources and transmits them to the Electronic Speed Controller (ESC). The Electronic Speed Controller (ESC) has the capability to receive speed information from the flight control unit and subsequently regulate the operation of all the Brushless Direct Current (BLDC) motors. RF (Radio Frequency) transmitting devices are utilised for the purpose of transmitting information into the ECB's network, allowing them to relay data and messages directly. A personal computer (PC) is connected to the ECB and performs all the complex calculations. The personal computer is connected to sensors for both sight and sound.

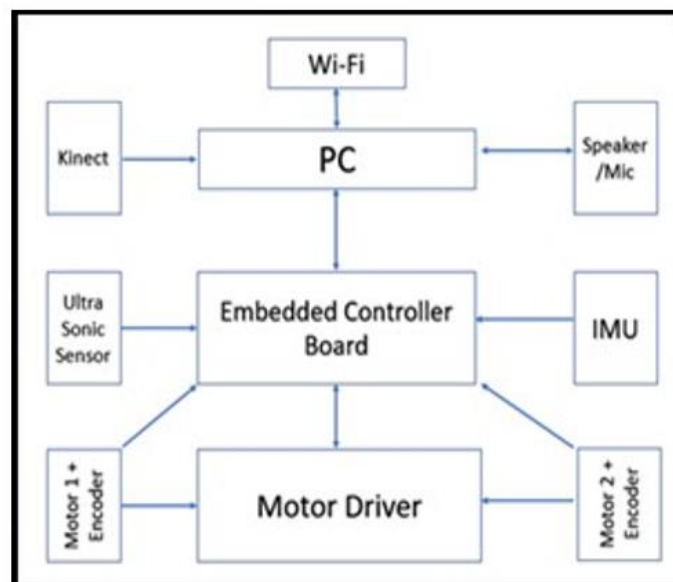

Figure 7: Constructive model of Robot

Via the utilisation of radio frequencies. The utilisation of an RC receiver is employed for the purpose of regulating the velocity of the BLDC motor. The Raspberry Pi (RPI) is a compact computer that incorporates wireless capabilities, including Bluetooth connectivity. It facilitates the acquisition of data from a camera and subsequently transmits this information to the flight controller, which in turn relays it to the ground level. The gimbal is employed to achieve camera alignment with respect to its intended subject. The Lidar Lite is a range Locator that is utilised for its drone-like attributes of high efficiency, extended range capabilities, and minimal acoustic disturbances. Additionally, it is employed for the determination of the quad-copter's altitude.

C. Robots

There are many stages of a pandemic in which robots are crucial. Robots allow healthcare workers to be located safely and effectively away from lonely patients. Robots of various types are used in various diagnostic and surgical procedures, greatly assisting human doctors and nurses. Robots are also useful in the pharmaceutical industry and in labs, where they assist human workers and thus reduce the risk of infection for doctors and scientists. When communicating with infected patients, robots [36] can also serve as a kind of intermediary. In Fig.7, a basic block diagram is depicted to explain how a medical robot operates.

Each robot has the following parts: two motors with encoders, a single motor driver, an embedded controller board, an ultrasonic sensor, an inertial measurement unit, a personal computer, a microphone and speakers, and Wi-Fi. The two motors are encoder-equipped and wired straight to the ECB. The number of motor revolutions is measured by an encoder. The motor driver is wired directly to the two motors and the electronic control board (ECB), which powers everything.

The system regulates the motor's speed. It uses ultrasonic sensors to detect obstacles and measure their distance from the vehicle, while inertial measurement unit (IMU) sensors refine and refine odometric calculations. Both sensors are hardwired

V. RECOVERY

The recovery phase holds significant importance within the course of a COVID-19 patient's journey towards regaining normalcy. During the recovery phase, a range of interventions are employed for the initial management, subsequent treatment, and overall recuperation of an individual who has contracted an infection. The recovery phase, as indicated by previous research [37], is widely recognised as the most challenging phase due to the necessity of swift and frequent implementation. During this stage, it is imperative to isolate the individual who has contracted the infection for a minimum duration of 14 days. Subsequently, administer the necessary medications to patients utilising diverse techniques based on the Internet of Things (IoT) in order to minimise direct human involvement with the individual receiving treatment. Ensuring comprehensive sanitization of the entire area poses a significant challenge in this particular scenario. These all changes can be minimized using IoT and web services

A. Wearables

Wearable Internet of Things (IoT) devices have the potential to assist in monitoring the condition of individuals who are infected, as well as others. Ensuring an appropriate distance between office workers and students attending educational institutions becomes particularly crucial following treatment, when such separation proves challenging.

- 1) *Smart Watches and Smart-Bands:* These gadgets help to keep constant tabs on vitals like heart rate, pulse, sleep duration, and temperature. These Internet of Things devices also aid in maintaining social distance by flashing red LED lights on users' faces whenever they make physical contact in a potentially hazardous environment. Smart bands [38], which are a collection of different Internet of Things devices can sense and capture data from other devices. They have a limited range and indicate their presence with LED lights if the person wearing them has a low heart rate or pulse. Because it is possibly a sign of covid-19 infection. The market for bands and smartwatches has grown rapidly since the covid-19 pandemic. Some of the contiguity detecting and wearable devices are shown in fig 8.
- 2) *Contiguity Detectors:* Currently, there is a return to normalcy as various industries resume operations and students resume their education at schools and colleges. Consequently, there is a concurrent escalation in the potential for transmission of contaminants among individuals. As the number of individuals venturing outside their residences increases, the likelihood of reduced adherence to social distancing measures will correspondingly rise. As a result of the presence of these contiguity detectors [39], individuals are able to focus on their tasks without concerns regarding the transmission of the virus.



Figure 8: Social Distancing Wearables

If the appropriate social distance is not maintained or when some patient is unexpectedly close, these devices will sound an alarm.

B. Drones

Drones are playing an increasingly important role [40] in the recovery phase and in different contexts. Drones are used for both commercial and recreational purposes at this stage, raising public consciousness about covid. Drones can be broken down into the following classes as discussed below:

- 1) *Multi-purpose Drones*: Instead of referring to different types of drones by different names, we can simply refer to them all as multipurpose drones. On the other hand, it could also be thought of as the sum of all possible types of drones.
- 2) *Monitoring Drones*: Curbing the global spread of viruses is high on the agenda of governments everywhere today. To verify the same, adequate measures are being taken to lessen interpersonal contact. Most nations took positive action, such as shutting down non-essential public spaces, outlawing large gatherings of people, and instituting a social distancing criterion to reduce interpersonal contact. The drones are very useful for surveillance and to ensure that people are adhering to the quarantine measures to combat the virus.
- 3) *Delivery Drones*: Drones with a cargo bay can transport samples to labs, deliver test results, and transport medical supplies to patients. In addition, people in the most remote areas, who lack reliable transportation, can benefit from drone deliveries of food and medicine. It's faster than driving and helps people keep their personal space while doing so.
- 4) *Sanitizing Drones*: Aerial spraying with disinfectants is being done with the help of sanitizing drones. The use of these drones makes the cleaning process quick and risk-free. These drones also restrict the expansion of human labor. The disinfectant is stored inside the drone, and its purpose is to take flight and spray the solution.
- 5) *Informative Drones*: When people in densely populated areas aren't obeying the government's newly enacted regulations, these drones can broadcast audio messages to educate them. Figure 9 depicts a few of the Drones.



Figure 9: Drones

C. Robots

Throughout the tertiary phase of the pandemic, robots serve in a variety of capacities, not just in hospitals but in other outlying areas as well. People are kept safely away from hazardous zones by robots. Robots in the market are also performing the duties of nurses in healthcare facilities. Robots' pandemic-related tasks can be categorized as follows

- 1) *Receptionist Robots*: Because there are more people infected with the virus as the global patient count rises, more people are likely to contract it through casual contact. Recent developments have seen the reopening of schools and a general return to normalcy following the lockdown; this includes the use of robot receptionists [41] in hospitals and other facilities to directly interact with patients and visitors. These robots guide patients and visitors around the hospital, providing accurate information without adding to the staff's workload.
- 2) *Cleansing/Disinfectant Robots*: To prevent the spread of disease, these robots are used to clean different areas of hospitals. These robots use a dry-cleaning and vacuuming process on medical equipment [42]. These machines can either spray disinfectant over an entire room or mop the floor using sanitizers. Fig.10 depicts a few examples of cleaning and disinfecting robots.
- 3) *Nurse/Surgical Robots*: The Japanese government developed nurse robots to help out in hospitals during the pandemic when doctors and nurses were too scared to treat the covid patients. As an intermediary between the patient and the physician, these [43] robots are invaluable. The use of these robots lessens the likelihood of contracting the disease. These robots serve a similar function to that of a nurse, assisting doctors in their work. Fig.11 depicts several types of surgical and nursing robots.

A list of robots with their features and the origin countries are discussed in table 2.



Figure 10: Cleansing/Disinfectant Robots



Figure 11: Surgical and Nurses Robots

<i>Food Ser.</i>	=	<i>Food Service</i>
<i>L. W.</i>	=	<i>Lab Work</i>
<i>Phar.</i>	=	<i>Pharmacy</i>
<i>Nur.</i>	=	<i>Nursing</i>
<i>Cl.</i>	=	<i>Cleaning</i>
<i>Waste Rem.</i>	=	<i>Waste Removals</i>
<i>Ref.</i>	=	<i>References</i>

D. Smart-Phone Applications

In this third stage, the applications' primary function is to provide and share the user's health information with relevant authorities and the user themselves. In this stage, regular use is made of rudimentary apps that serve to check symptoms. Some of these apps also advise on what to do in terms of medical care based on whether or not the user exhibits symptoms of the virus, and if they do, what those symptoms might be.

Table II: List of Robots

Robots	Origin Country	Food Ser.	L. W.	Phar.	Nur.	Cl.	Waste Rem.	Ref.
TUG	Aethon(USA)	Yes	Yes	Yes	Yes	•	Yes	[44]
Moxi	Diligent Robots(USA)	•	•	Yes	Yes	•	•	[45]
Roomba i7	i7 Robots(USA)	•	•	•	•	Yes	•	•
RP-Vita	i7 Robots(USA)	•	•	•	Yes	•	•	•
Relay	Swisslog(Switzerland)	Yes	Yes	Yes	•	•	Yes	[46]
Dinsow	CT Asia (Thailand)	•	•	•	Yes	•	•	•
Ambubot	Thailand	•	•	Yes	Yes	•	•	[47]
RIBA	Japan	•	Yes	•	Yes	•	•	•

- 1) *HaMagen*: The Israeli Ministry of Health has released this mobile application. This software employs a method of tracking infected individuals through their networks of contacts. Almost two weeks' worth of data on the infected person can be found in this app. Users' location histories and other data are transmitted to authorities via this app. If HaMagen discovers that a user has come into contact with someone who is ill or infectious, it will send them the necessary information.
- 2) *Stop Corona App*: The Croatian Ministry of Health introduced this app. Each user's daily movements and contact updates are recorded by this app. This app can also generate health reports based on a person's symptoms, which can be submitted or obtained. Further, it aids government efforts to locate potentially hazardous contaminated areas.

VI. IOT'S IN VACCINATION

Many nations like India, the United States, the United Kingdom, Russia, and nearly every other nation with one of the best healthcare infrastructures have started distributing COVID-19 vaccines after fighting the pandemic for almost a year. An efficient vaccine rollout is even more important as daily infections rise and lockdowns have a negative impact on people's lives. The IoT is assisting authorities in this. Additionally, the use of IoT in the healthcare sector began long before the COVID-19 pandemic. IOTs play important roles in the manufacture and distribution of vaccinations in a variety of ways as discussed below:

A. Increased Productivity

A manufacturing facility's IoT devices can collect data that demonstrates how the facility can be made more effective. Due to social distance requirements, many facilities are currently unable to have their entire workforce present in the same location at once. For these plants, automation can fill in the gaps, and IoT devices enhance automated machines.

B. Supply Chain Openness

Transporting and storing vaccines is one of the biggest problems facing vaccine rollouts. Since vaccine storage must be done at extremely low temperatures, such as -20°C to -70°C . IoT sensors are considerable in the temperature monitoring process. Additionally, these gadgets/sensors can remotely check the temperature and other conditions inside trucks and storage facilities to see if anything needs to be changed. These features also guarantee the security of their vaccines

C. Managing Data after an Injection

IoT devices can be useful even after a patient has received a shot. Patients can use wearables to be informed about the Covaxin and CoviShield vaccines and shots' timing. In addition, IoT devices can assist hospitals in improving the efficiency of their record-keeping procedures. The more effectively these practices are implemented, the better hospitals can track vaccination records. As a result, the overall vaccine rollout will be more successful [48].

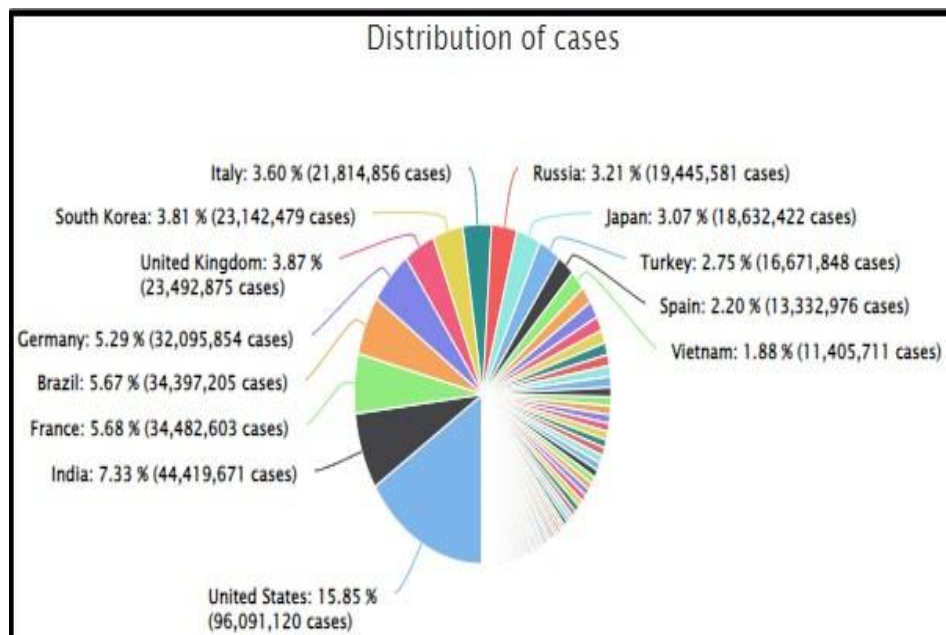

Figure 12: Distribution of Cases

VII. ROLE OF WEB SERVICES

Web services can be described as a compilation of various standards and open techniques that facilitate the transfer of data between programmes or systems. A web service can also be characterised as a user interface that delineates a set of operations and executes a specific type of task. The web service is delineated using a conventional formal XML notation [49], which encompasses indispensable particulars that are obligatory for engaging with the service, encompassing the format of messages. The usage of these services in pandemics and their operations during various phases are discussed below:

A. Tracking Phase

Web services such as www.worldometer.info [50] provide real-time global statistics pertaining to various aspects of the world, including population, government, economy, society, media, surroundings, water, energy, food, and medical care. Additionally, it provides intriguing statistical data through a global population counter clock, the annual deforestation rate, the concentration of carbon dioxide (CO₂) emissions in the atmosphere, the report on global hunger, and the aggregate energy consumption. Moreover, numerous statistical data pertaining to various significant facets of the world are currently facilitating individuals in accessing real-time analyses of the number of COVID-19 cases within specific geographical regions. The cases are regularly updated and can be accessed directly on the website. The website employs JavaScript and HTML5 as its fundamental programming languages, and has made the source code publicly available for the purpose of facilitating collaboration among developers in creating applications and websites aimed at addressing various health-related concerns, including the management of the COVID-19 pandemic. Fig 12 shows the

distribution on cases among countries having a larger population including the US, India, Russia etc. This chart helps to identify which country is most infected by covid-19. Also, Fig 13 shows the real-time data of everyday Covid patients worldwide Blue-dot global [51] has been collecting data from multiple pharmaceutical and medical publications worldwide.

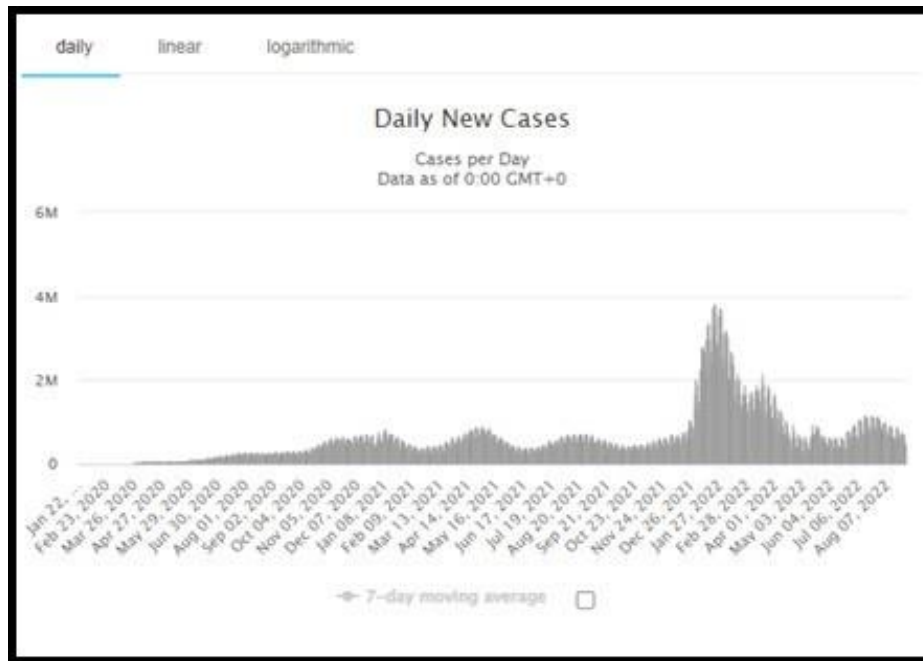

Figure 13: Daily New Cases

They have then utilised various Artificial Intelligence methodologies to analyse this data and detect the evolving trends and indicators associated with the COVID-19 pandemic. The primary objective of this data harvesting endeavour is to leverage big data in order to promptly identify any global outbreak. Moreover, it possesses the ability to predict the global dissemination of disease outbreaks and the potential ramifications that may be encountered by the general population as a result of such outbreaks.

B. Diagnosis Phase

Several companies utilised machine learning methodologies to conduct an analysis of human chest radiographs with the objective of identifying preliminary indications of coronavirus infection. Certain innovators have utilised artificial intelligence (AI) and machine learning (ML) techniques to discern X-ray films that bear resemblance to those of patients with Covid-19. These films are then prioritised for prompt review by medical professionals, thereby reducing the duration of treatment for infected individuals who have been diagnosed. For instance, the technique was also implemented by UC San Diego Health Systems.

C. Recovery Phase

Web-based platforms such as symptomate.com and patient.info facilitate self-diagnosis by offering comprehensive information regarding various symptoms. Upon thorough analysis of

the symptoms, individuals can seek appropriate treatment from a specialised medical practitioner. This is a guide outlining the process by which patients can receive medical treatment from the comfort of their own homes, thereby bypassing the need to visit a healthcare professional in person. These services are available around the clock, without any need for scheduling appointments.

Numerous pharmaceutical companies have also established an online presence through web services in order to offer their services to individuals in need on a global scale.

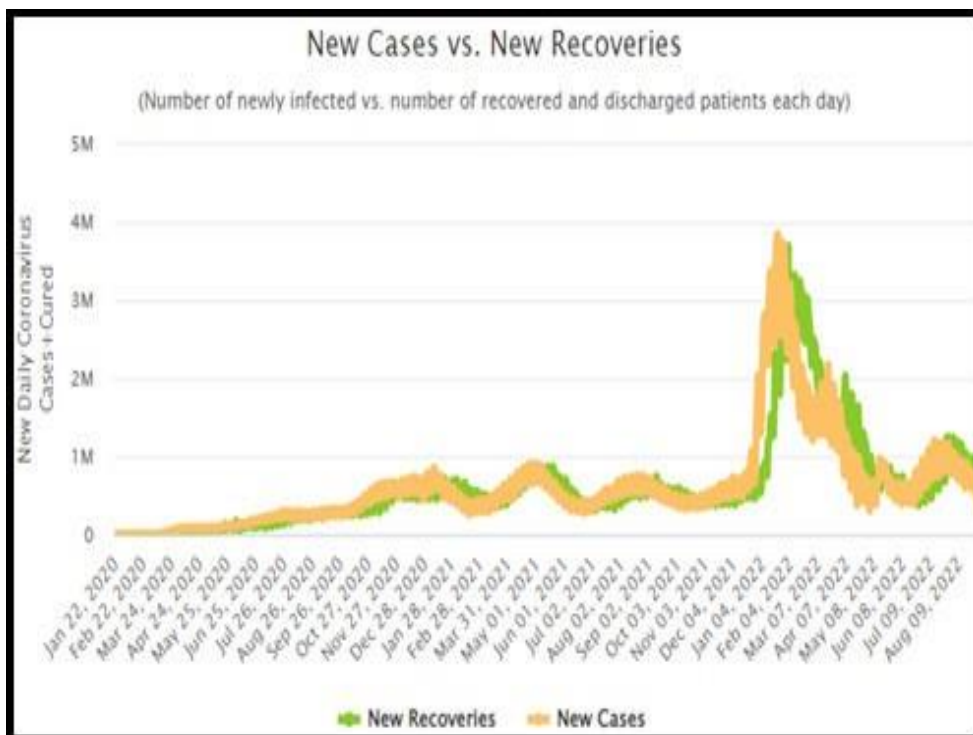

Figure 14: New cases vs New Recoveries

Online platforms such as netmeds.com, medlife.com, and other similar entities have significantly facilitated the process of purchasing medications through digital means, thereby enhancing accessibility for individuals. In response to the global pandemic, the organisation is implementing various measures such as providing special promotions and expedited delivery services for pharmaceutical products to better serve patients. These online platforms have established a dedicated section for individuals diagnosed with COVID-19 who are in need of medications specifically related to the virus. This allows individuals to bypass the requirement of obtaining a prescription from a healthcare professional and directly access the necessary medications for self-treatment during the early stages of the illness. A description of recovery of corona patients is shown in fig.14 with respect to new cases.

Other Aspects: In addition, numerous online platforms facilitate the examination of the phenomenon wherein city centres have experienced a decline in human presence, leading to a greater reliance on online services as opposed to offline alternatives. Furthermore, the utilisation of data obtained from web services has facilitated the expansion of local enterprises, enabling them to enhance their operations with greater ease and convenience. The online presence of local businesses is experiencing steady growth as individuals are increasingly adhering to stay-at-home measures in response to the significant surge in COVID-19 cases. In addition, web services facilitate the growth of local businesses and aid individuals in adhering to social distancing measures. Additional crucial measures that are required to prevent the transmission of the virus to one's body can also be maintained. Various countries have requested popular binge-watching platforms such as Netflix, Prime Video, Hotstar, and other streaming services to reduce the cost of their premium streaming plans.

The intention behind this request is to encourage individuals to remain at home for extended periods of time. Additionally, the decrease in prices has resulted in an increase in the number of users for each streaming platform. This has alleviated the burden on both governments and individuals. In crowded areas, there are several tools employed to detect individuals who may be infected, such as smart glasses and helmets. The utilisation of Internet of Things (IoT) technology facilitates government officials in identifying and locating containment zones. In the restrictions situation when nobody was allowed to move out of their homes, there were IoTs only which helped people to convey with others and acquire essential amenities within their households. The absence of IoT in the world would pose significant challenges in effectively managing such situations.

VIII. CONCLUSION

Every person on this planet, including doctors and scientists, is impacted by the fight against COVID-19. To combat the pandemic, a greater number of technological solutions have been developed and implemented. The IoT and web services in general are extremely important tools in the fight against this terrible disease. In this paper, we study different IoT architecture and web services further understanding their utility in COVID-19. The entire scenario was broken down into these four stages. 1. Tracking and tracing, 2. Detecting, and 3. Recovery, and 4. IoT vaccination phase. During the first three stages of the COVID scenario, we investigated IoT systems and their deployment.

These technologies included wearables, robotics, drones, and applications. Additionally, we investigated the role that web services play in the global distribution of data and information. Therefore, both techniques offer a response that is quite adequate for this kind of circumstance. Consequently, more effective utilization of these technologies will be of assistance in the treatment of people, the management of data for and about people, as well as the recovery of patients. Since the authorities have active access to these tools, therefore, they can respond more quickly and provide treatment and care for a greater number of people. Resultantly, in a lower rate of deaths and hospitalizations caused by the infection.

References

- 1) Gokhale, Pradyumna, Omkar Bhat, and Sagar Bhat. "Introduction to IOT." International Advanced Research Journal in Science, Engineering and Technology 5.1 (2018): 41-44.
- 2) Liu, Yu, et al. "Combination of cloud computing and internet of things (IOT) in medical monitoring systems." International Journal of Hybrid Information Technology 8.12 (2015): 367-376.
- 3) Perwej, Dr. Yusuf & Haq, Kashiful & Parwej, Dr. Firoj & M., Mumdouh. (2019). The Internet of Things (IoT) and its Application Domains. International Journal of Computer Applications. 182. 3649. 10.5120/ijca2019918763.
- 4) Introduction to Web Service Technologies. (2021). https://docs.oracle.com/cd/E13224_01/wlw/docs100/guide/webservices/conBasicWebServiceTechnologies.html. Accessed Aug 20, 2022
- 5) NCIRD (2019), 1918 Pandemic (H1N1 virus). <https://www.cdc.gov/flu/pandemic-resources/1918-pandemic-h1n1.html>
- 6) The deadliest viruses in history. (2021) <https://www.livescience.com/56598-deadliest-viruses-on-earth.html>. Accessed, Aug 15, 2022.
- 7) Prevention and Vaccine of Ebola Virus. (2021) <https://www.cdc.gov/vhf/ebola/prevention/index.html>. Accessed, Aug 16, 2022.
- 8) HIV Basics and Treatment, (2021) <https://hivinfo.nih.gov/understanding-hiv/fact-sheets/hiv-treatment-basics>. Accessed, Aug 15, 2022
- 9) Signs and symptoms of Hantavirus Pulmonary syndrome, (2021). <http://www.medicinenet.com/hantaviruspulmonarysyndrome/article.html>. Accessed Aug 16 2022.
- 10) SARS Vaccine Development, (2005) <https://www.ncbi.nlm.nih.gov/pmc/articles/PMC3371787/>. Accessed, Aug 16, 2022
- 11) Rotavirus Vaccination, (2018) <https://www.cdc.gov/vaccines/vpd/rotavirus/index.html>. Accessed, Aug 16, 2022.
- 12) Vaishya, Raju, et al. "Artificial Intelligence (AI) applications for COVID 19 pandemic." Diabetes & Metabolic Syndrome: Clinical Research & Reviews 14.4 (2020): 337-339.
- 13) Salman, Fatima M., et al. "Covid 19 detection using artificial intelligence." (2020).
- 14) Javaid, Mohd, and Ibrahim Haleem Khan. "Internet of Things (IoT) enabled healthcare helps to take the challenges of COVID 19 Pandemic." Journal of Oral Biology and Craniofacial Research 11.2 (2021):
- 15) Nasajpour, M., Pouriyeh, S., Parizi, R.M. et al. Internet of Things for Current COVID-19 and Future Pandemics: an Exploratory Study. J Healthc Inform Res 4, 325–364 (2020).
- 16) Krishna Kumar, Narendra Kumar, Rachna Shah, Role of IoT to avoid spreading of COVID-19, International Journal of Intelligent Networks, Volume 1, 2020, Pages 32-35, ISSN 26666030
- 17) Wearable Helmets with Thermal Camera's (2020), <https://kcwearable.com/>. Accessed, Aug 16, 2022.
- 18) Smart wearable goggles, (May, 2020) <https://www.wearable-technologies.com/2020/05/vuzix-m400-smart-goggles-continue-their-expansion-into-remote-care-for-covid-19-patients/>. Accessed Aug 17, 2022.
- 19) Track the spread of Corona Virus with Smart Thermometers, (May, 2020) <https://www.opthalmologytimes.com/view/covid-19-smart-thermometer-shows-real-time-changes-in>

- fever-levels. Accessed Aug 17,2022.
- 20) Covid-19 Scenario- Emerging use of Drones in India, (April, 2020)
<https://ficci.in/SEDocument/20500/COVID-19-Drones.pdf>. Accessed Aug 17,2022.
 - 21) sssAutomated Robots Safe Covid-19 Testing, (June,2020),
<https://www.medgadget.com/2020/06/automated-robot-takes-swabs-for-safe-covid-19-testing.html>.
Accessed Aug 17, 2022.
 - 22) Top Smartphone apps to track covid-19, (April,2020) <https://www.geospatialworld.net/blogs/popular-apps-covid-19/>. Accessed Aug 17,2022.
 - 23) Shield for Safer India, (April,2020) <https://aarogyasetu.gov.in/> Accessed Aug 17, 2022.
 - 24) Trace Together Safer Together, (April,2020)<https://www.tracetogether.gov.sg/>. Accessed Aug 17, 2022
 - 25) Together we stop covid-19, (Aug 2020)<https://www.wehealth.org/arizona>. Accessed Aug 17, 2022
 - 26) Corona Dataspende App, Germany (April 2020), <https://corona-daten-spende.de/> Accessed Aug 17, 2022
 - 27) Shield for Safer India, (April,2020) <https://aarogyasetu.gov.in/> Accessed Aug 17, 2022
 - 28) Corona Dataspende App, Germany (April 2020), <https://corona-daten-spende.de/> Accessed Aug 17, 2022.
 - 29) Trace Together Safer Together, (April,2020)<https://www.tracetogether.gov.sg/>. Accessed Aug 17, 2022.
 - 30) Together we stop covid-19, (Aug 2020)<https://www.wehealth.org/arizona>. Accessed Aug 17, 2022.
 - 31) Israeli Phone Apps Aim to Track Covid : HaMagen (April 2020)<https://www.usnews.com/news/best-countries/articles/2020-04-20/new-tech-apps-in-israel-aim-to-track-coronavirus-guard-privacy>. Accessed Aug 17, 2022
 - 32) Moscow To Launch New Surveillance App To Track Residents In Coronavirus Lockdown, (April2020)
<https://www.npr.org/sections/coronavirus-live-updates/2020/04/01/825329399/moscow-launches-new-surveillance-app-to-track-residents-in-coronavirus-lockdown>. Accessed Aug 17, 2022
 - 33) United Against Covid-19, Stop Corona App (Croatia, June 2020),<https://stopcorona.app/> Accessed Aug 17, 2022
 - 34) How drones are being used to combat covid-19 (April 2020), <https://www.geospatialworld.net/blogs/how-drones-are-being-used-to-combat-covid-19/>. Accessed Aug 17, 2022
 - 35) Rabah, Mohamed and Rohan, Ali and Talha, Muhammad and Nam, Kang-Hyun and Kim, Sung. (2018). Autonomous Vision-based Target Detection and Safe Landing for UAV. International Journal of Control, Automation and Systems. 16. 3013-3025. 10.1007/s12555-018-0017-x. Mohamed Rabah, Autonomous Vision-based Target Detection and Safe Landing for UAV, Flight Controller(Pg-3 Para 2.1)(Dec,2018) ,
t.ly/vTXz
 - 36) How Robots Became Essential Workers in the COVID-19 Response, (Sep,2020),
<https://spectrum.ieee.org/how-robots-became-essential-workers-in-the-covid19-response>. Accessed Aug 18, 2022
 - 37) Coronavirus Recovery, Hansa D.Bhargava (April 2020) <https://www.webmd.com/lung/covid-recovery-overview-3>. Accessed Aug 19, 2022.
 - 38) Coronavirus: 9 smartwatches and fitness bands that can help 'monitor' oxygen level, (Sep 2020)
<https://www.gadgetsnow.com/slideshows/coronavirus-9-smartwatches-and-fitness-bands-that-can-help-monitor-oxygen-level/photolist/76843552.cms>. Accessed Aug 19,2022.

- 39) Proximity Detection and Contact Tracing for Covid-19, <https://www.actility.com/proximity-detection-contact-tracing-for-covid-19/>. Accessed Aug 19,2022.
- 40) Drones and the Coronavirus, (April 2020) <https://blog.werobotics.org/2020/04/09/drones-coronavirus-no-sense/>. Accessed Aug 19,2022
- 41) Robot receptionists introduced at hospitals in Belgium, (2016), <https://www.theguardian.com/technology/2016/jun/14/robot-receptionists-hospitals-belgium-pepper-humanoid>. Accessed Aug 20,2022.
- 42) Roomba Robot Vacuums and braava mopping robot, (Mar 2020) <https://www.irobot.in/>. Accessed Aug 20,2022.
- 43) Robotic Nurses, (2010) <https://cs.stanford.edu/people/eroberts/cs201/projects/2010-11/ComputersMakingDecisions/robotic-nurses/index.html>. Accessed Aug 20,2022.
- 44) Aethon Robots, (March, 2020) , <https://aethon.com/mobile-robots>. Accessed Aug 20,2022.
- 45) Diligent Robotics, (March 2020) <https://www.diligentrobots.com/moxi>. Accessed Aug 20,2022.
- 46) Swisslog Healthcare, (Mar, 2020) <https://www.swisslog-healthcare.com/en-us/products-and-services/transport-automation/relay-autonomous-service-robot>. Accessed Aug 20,2022.
- 47) M. Arif and H. Samani, "AMBUBOT: Ambulance robot Automated External Defibrillator robotic ambulance," 16th International Conference on Advanced Communication Technology, 2014, pp. 58-66,
- 48) Covid 19 vaccine: The Role of IoT, <https://www.iotforall.com/the-role-of-iot-for-the-covid-19-vaccine>. Accessed Sep 22, 2022
- 49) Gottschalk, K. and Graham, S. and Kreger, Heather and Snell, J.. (2002). Introduction to Web services architecture. IBM Systems Journal. 41. 170 177.
- 50) Worldometer (Aug, 2022), <https://www.worldometers.info/coronavirus/>. Accessed Aug 22, 2022.
- 51) Bluedot global, (Nov,2020), Anticipate outbreaks, mitigate risks, Build Resilience. <https://bluedot.global/>. Accessed Aug 22, 2022.209-214.